



BOLTING TOOLS



Tools for every conceivable need.....

www.powermasteramerica.com



carries the worlds most comprehensive line of Industrial Bolting Tools. Whether you need manual or hydraulic, air driven or electric - We are your one stop shop for all your Bolting needs.



for years has been recognised as a significant world player in the manufacture and supply of quality Hydraulic Torque Wrenches, Pumps and Accessories for the Power, Mining, Refinery, Steel, Petrochemical and other Heavy Industries.

Corporate Headquarters

26, Russell Park Road,
Syosset, New York 11791,
Phone : +1 516.503.5294

Web: www.powermasteramerica.com
Email: sales@powermasteramerica.com

Distribution available in over 110 countries worldwide.

POWER SPLITTERS

For Removing Frozen Nuts The Right Way

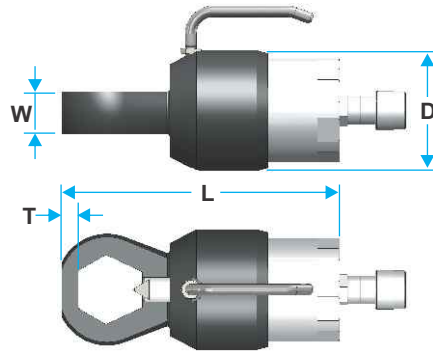

Standard Series

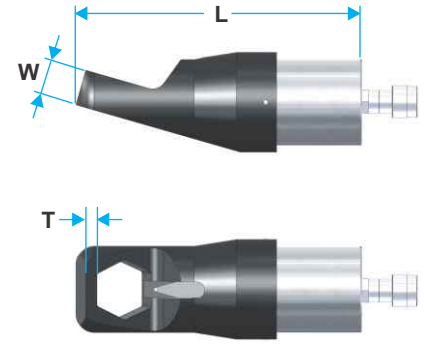

Angle-Head Series

Features :

- No spark or flame. No risk to volatile surrounding.
- Triangular Chisel providing three cutting edges.
- Light and compact design for ease of operation and handling.
- Dedicated cylinder with minimal stroke for faster operation.
- Rear end connection for ease of handling and safe-connection.
- Laser marked for easy setting. No separate spacer for each Nut.
- 700 bar working pressure.
- Calibrated system. No damage to stud / bolt threads.



Model No.	Stud Size		Nut A/F Size		Load Ton	L Max. mm	D mm	T mm	W mm	Weight Kg.
	mm	inch	mm	inch						
NS-012AH*	6 - 12	1/4 - 1/2	7 - 22	1/4 - 7/8	5	135	45	7	19	1.4
NS-100AH*	11 - 16	7/10 - 5/8	13 - 24	1/2 - 1	10	196	73	9	19.5	3.4
NS-105	11 - 22	7/16 - 7/8	16 - 36	5/8 - 1.7/16	25	256	106	13.5	36	9.6
NS-200	22 - 32	7/8 - 1.1/4	36 - 51	1.7/16 - 2	25	256	108	14.5	38	10
NS-204	32 - 38	1.1/4 - 1.1/2	46 - 60	1.13/16 - 2.3/8	50	329	154	18.2	50	25
NS-210	35 - 45	1.3/8 - 1.3/4	57 - 70	2.1/4 - 2.3/4	50	357	154	20	51	26.5
NS-308	45 - 57	1.3/4 - 2.1/4	70 - 89	2.3/4 - 3.1/2	100	395	200	21	74	49.5
NS-314	50 - 64	2 - 2.1/2	79 - 88	3.1/8 - 3.7/8	100	496	202	23	78	52.5
NS-404	64 - 70	2.1/2 - 2.3/4	95 - 108	3.3/4 - 4.1/4	150	450	246	32	89.5	81.5
NS-500	76 - 83	3 - 3.1/4	114 - 127	4.1/2 - 5	150	456	250	32	98	87.5
NS-506	83 - 89	3.1/4 - 3.1/2	124 - 136	4.7/8 - 5.3/8	150	470	250	40	105	93.5

* Angle Head.

Power-splitters can be used / supplied with a variety of Hand-pumps, Electric-Pumps or Air-Operated Pumps.

HAND PUMP

This hand pump is specially designed for Splitter applications. The pump is compact and light in weight with longer handle needing very little effort to generate max working load.

Model No.	Max Pressure	Flow Rate cc	Type	Oil Tank Cap.	Size
	bar			liters	cm
PM-HP10-1	700	2.8	Single Stage	1.8	56 x 16 x 19
PM-HP10-2	700	2.8	Single Stage	2.2	71 x 16 x 20
PM-HP14-2	950	2.8	Single Stage	2.2	71 x 18 x 20
PM-HP10-3D	700	49/2.8	Double Stage	3.0	50 x 18 x 35
PM-HP10-5D	700	49/2.8	Double Stage	5.0	50 x 18 x 35



POWERMASTER AMERICA LLC.

26, Russell Park Road, Syosset, New York 11791.

Phone : +1 516.503.5294

Web: www.powermasteramerica.com Email: sales@powermasteramerica.com